

FECOM

THIRD ANGLE
PROJECTION

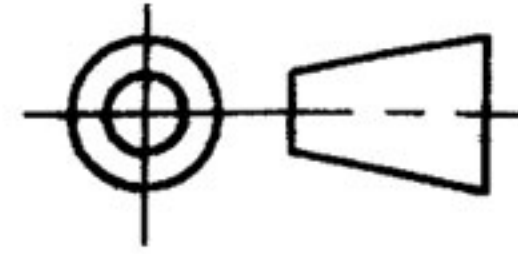

REMOVE ALL BURRS
& SHARP EDGES

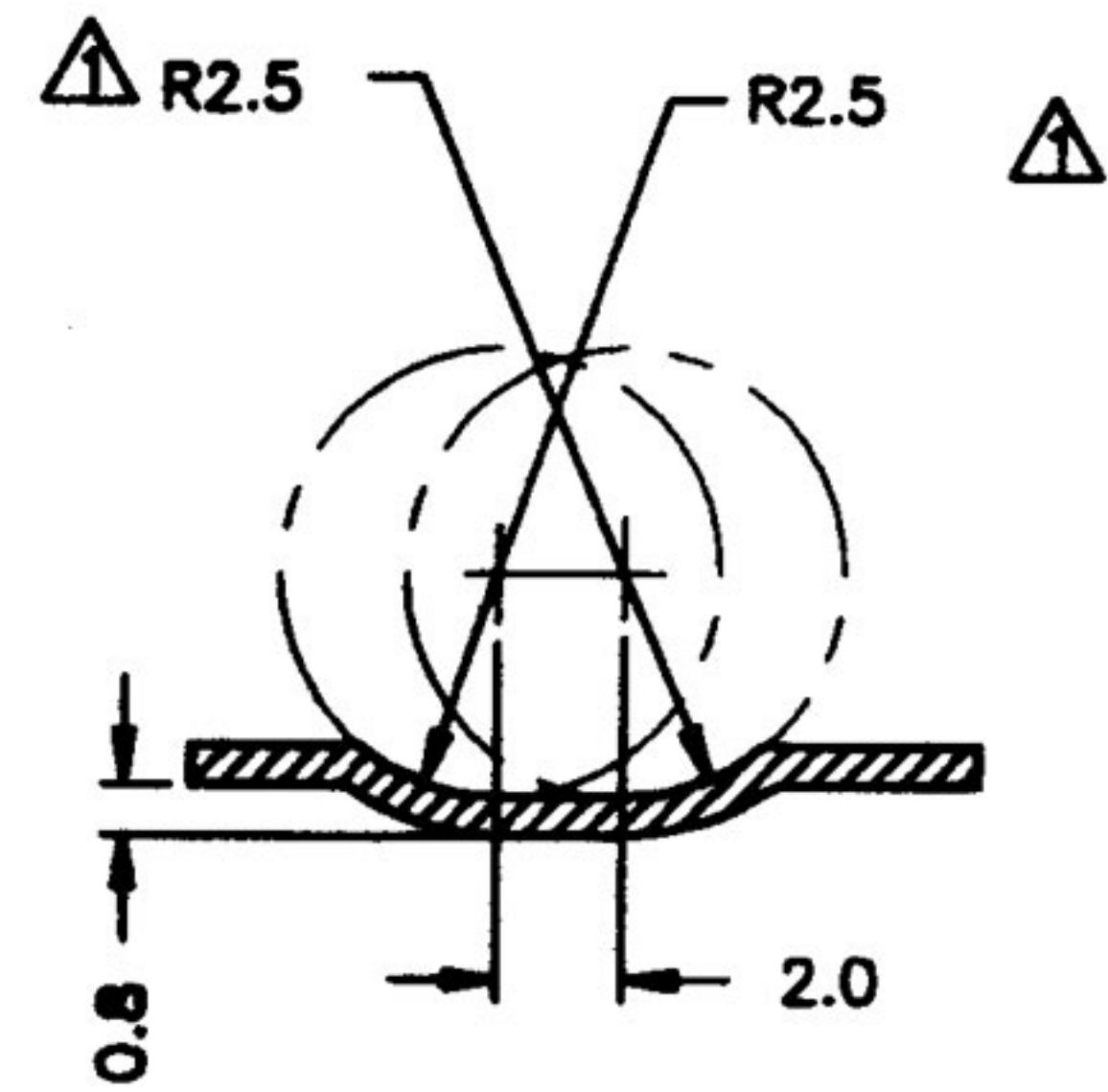
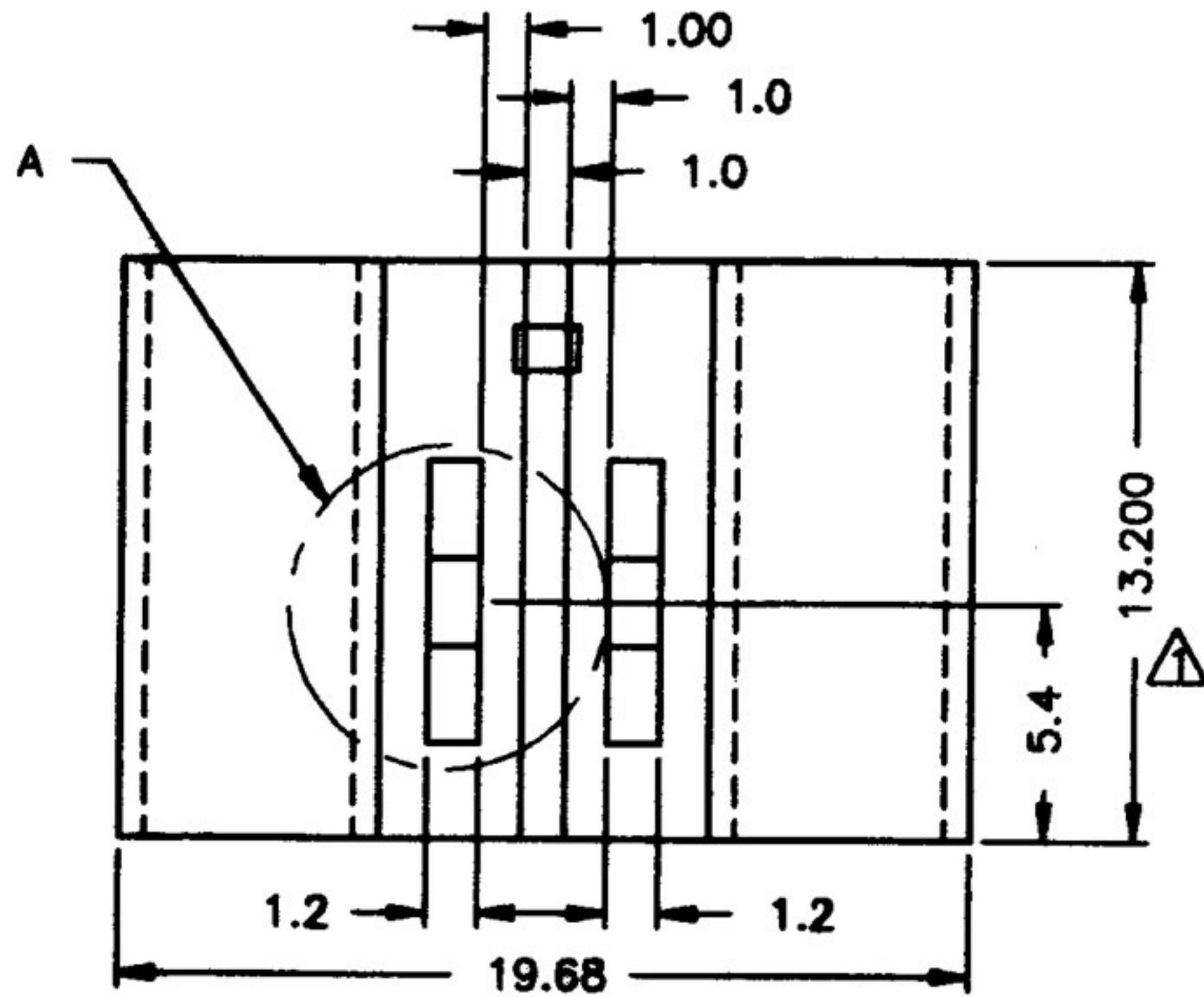

DETAIL A

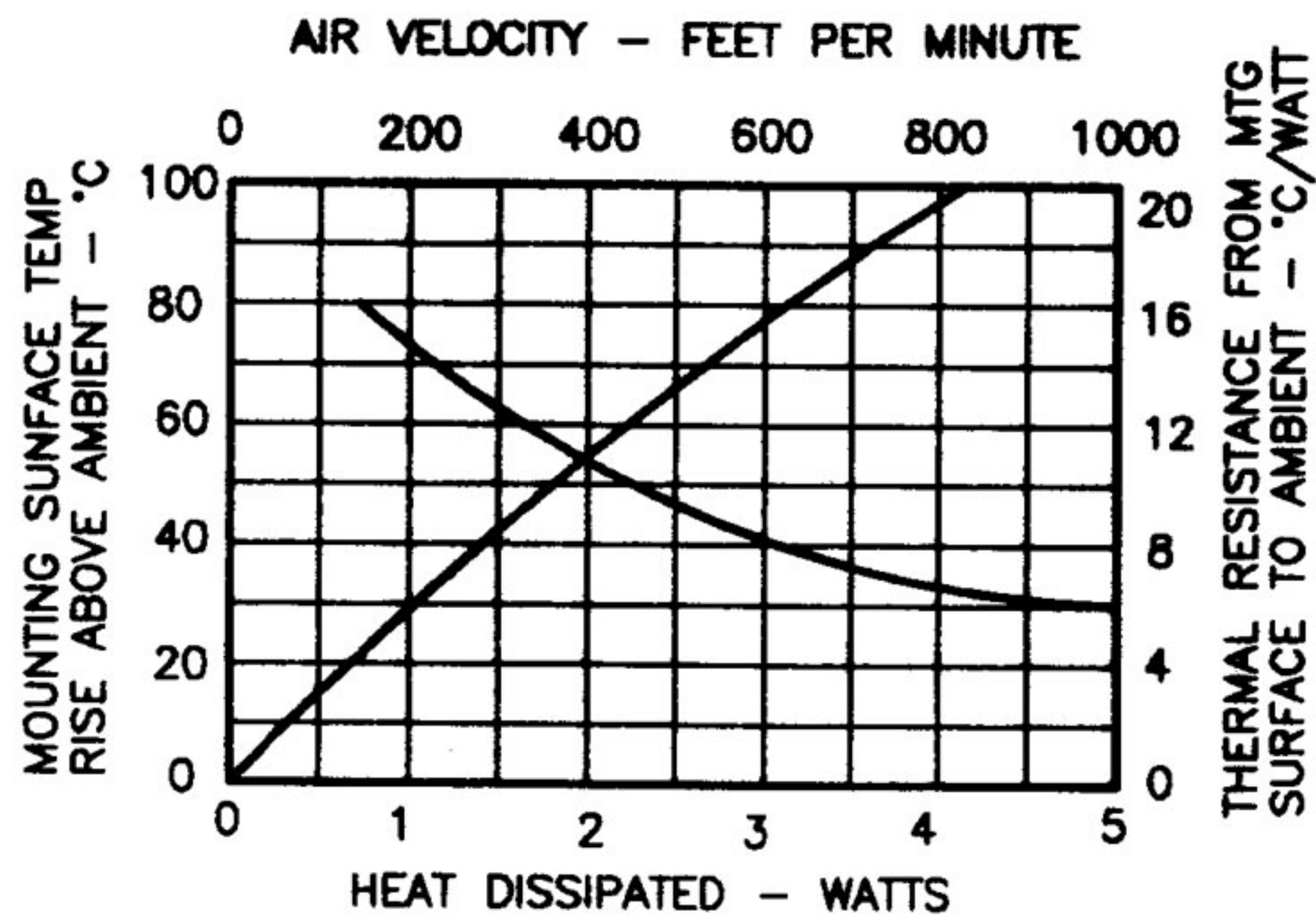
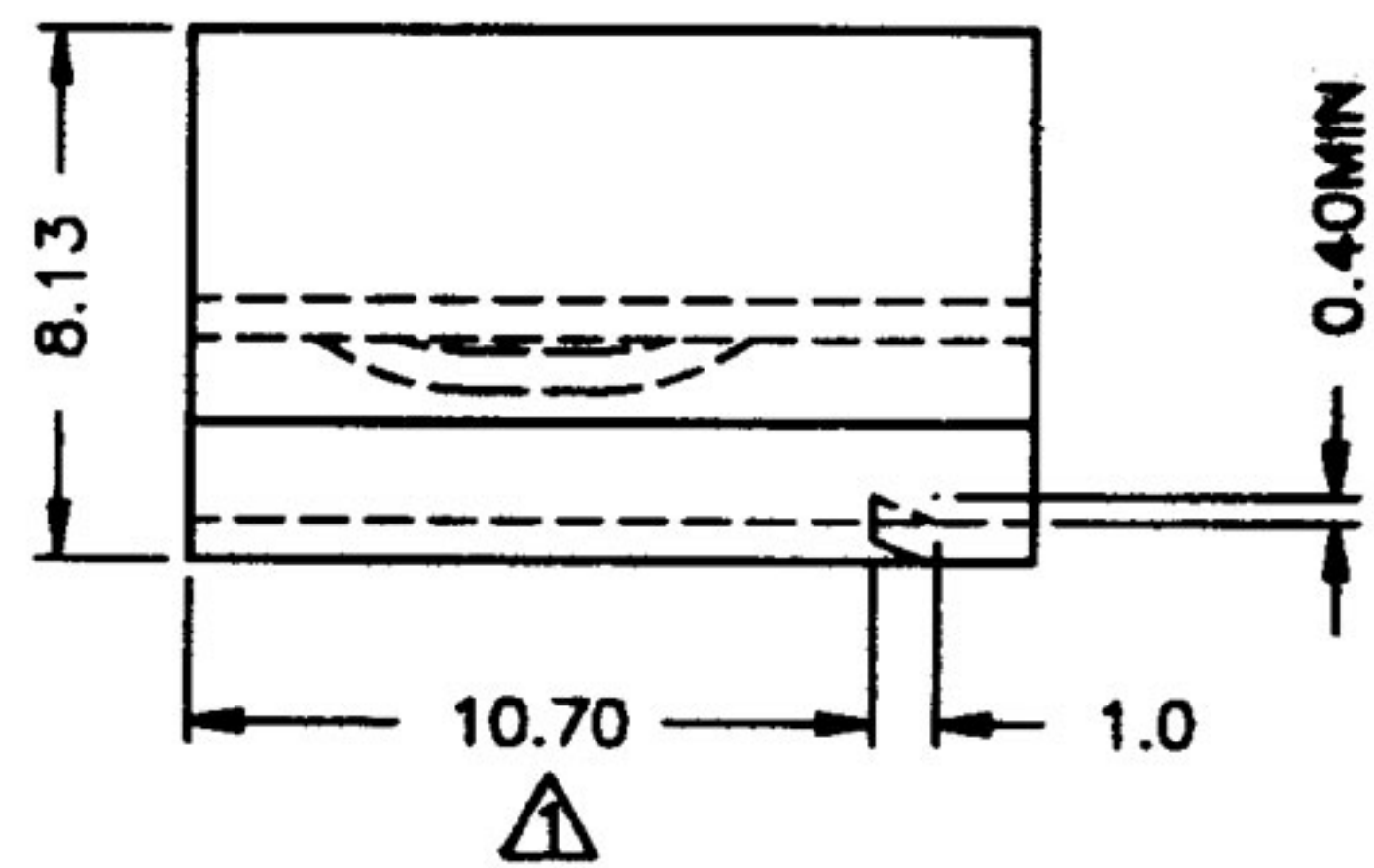
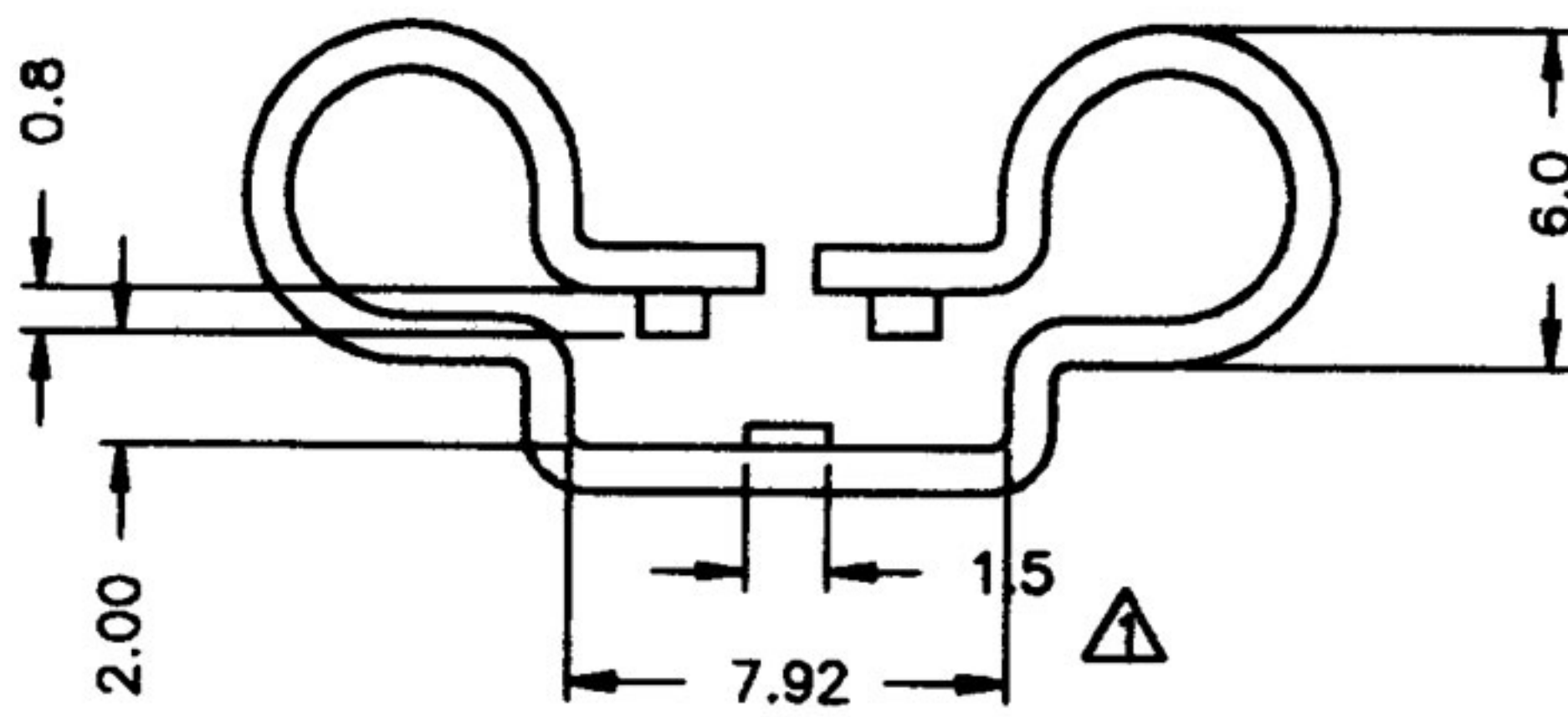

MATERIAL: AL5052

FINISH: BLACK ANODIZE

HEAT SINK

FECOM P/N: FE-T220-0058