

FECOM

THIRD ANGLE PROJECTION  REMOVE ALL BURRS & SHARP EDGES

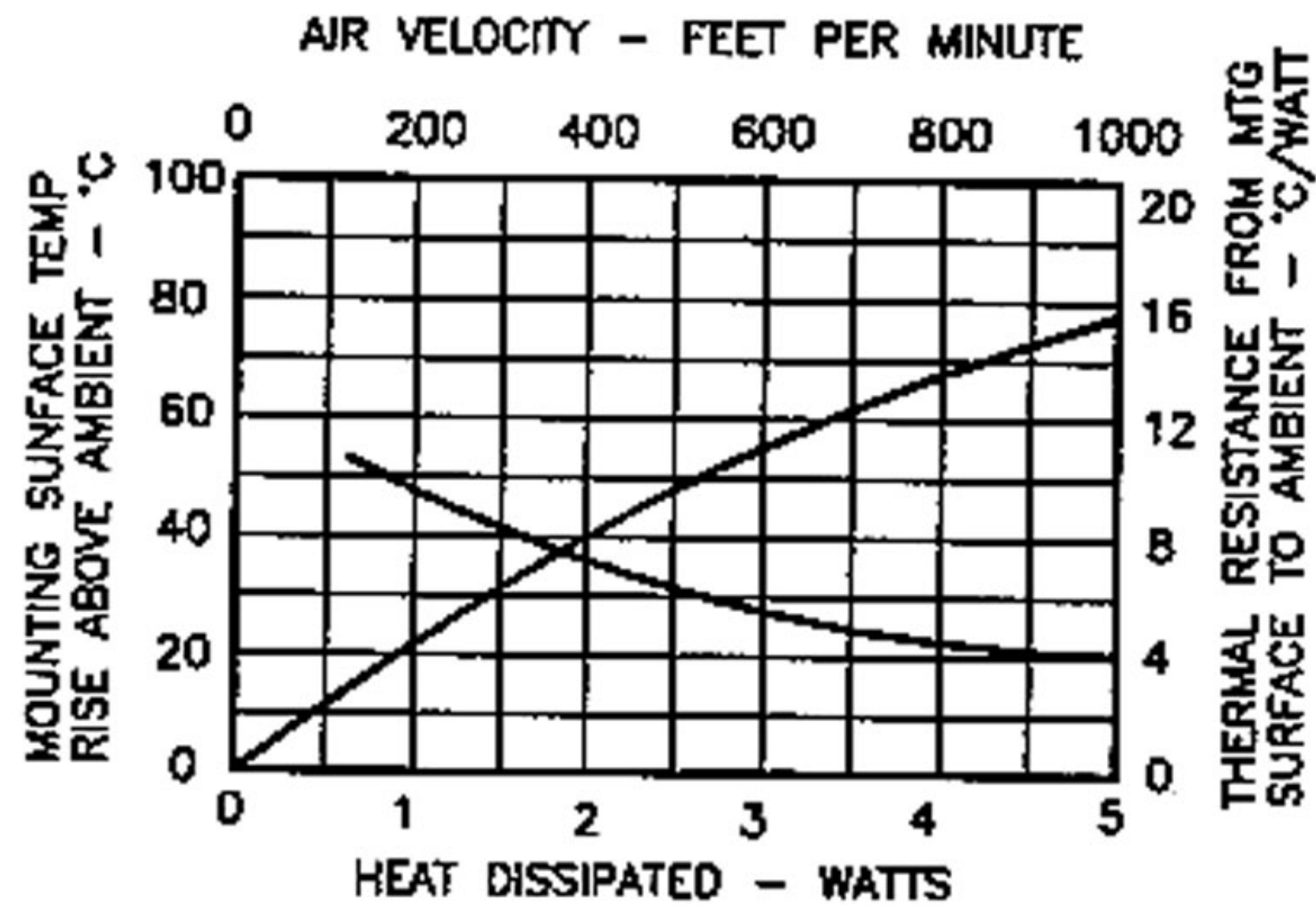
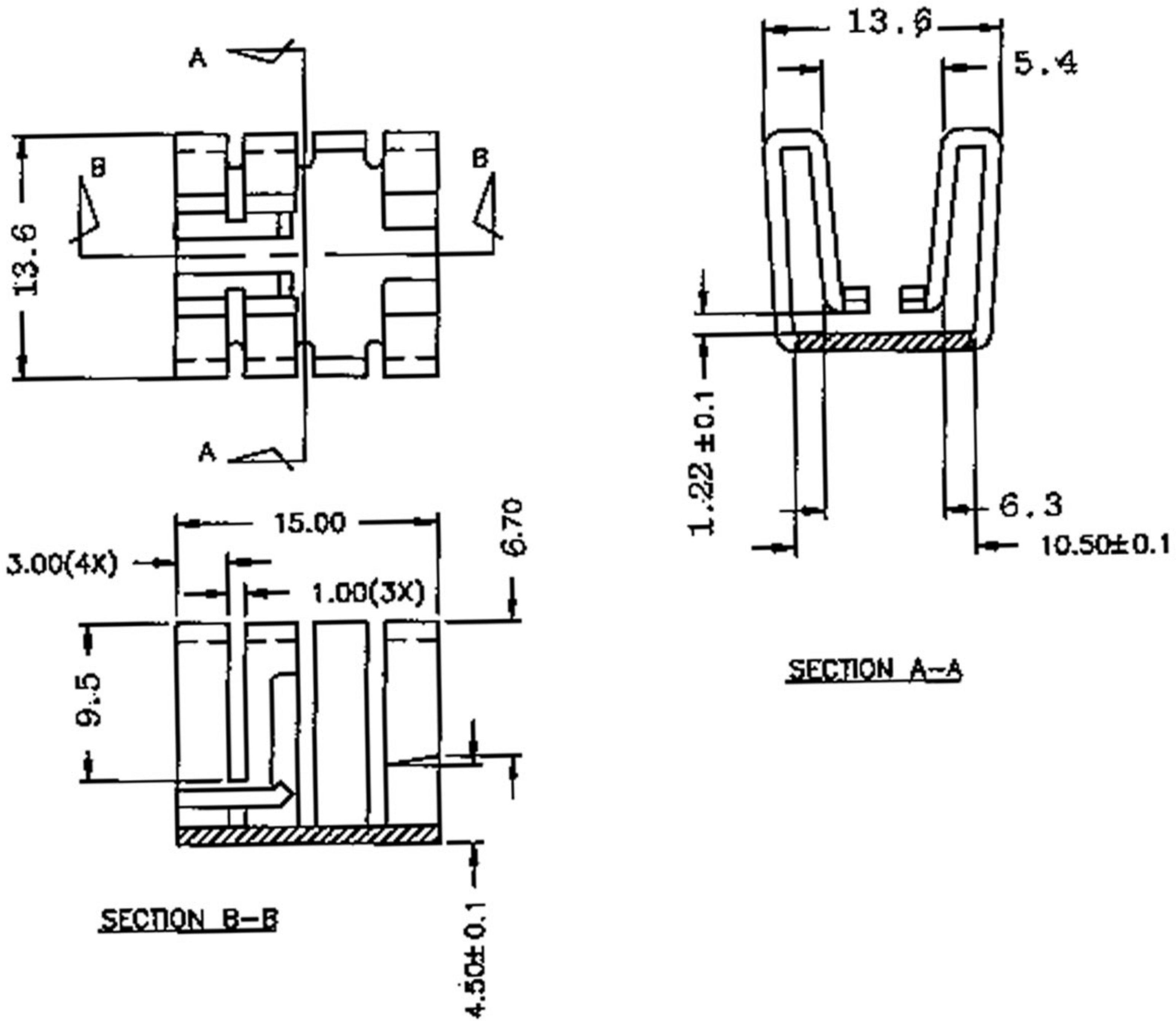

MATERIAL: AL5052

FINISH: BLACK ANODIZE

HEAT SINK

FECOM P/N: FE-T220-0040-03